

DATE
Sept. 8, 2005
CAT. #: EPO102-50

OUTLINE DIMENSIONS
3-PHASE INDUCTION MOTOR

MOTOR TYPE:
AEHH8N
FRAME NO. 215T

Pole	HP	kW	Hz	VOLT	Syn. Speed r/min(rpm)
2	10	7.5	50	190/380	3000
Ins	Rating	Dimension in	Approx Weight	Bearings	
F	CONT.	inches	190 lbs.	DE: 6308ZZ	NDE: 6306ZZ

Totally Enclosed Fan Cooled Squirrel Cage Rotor.

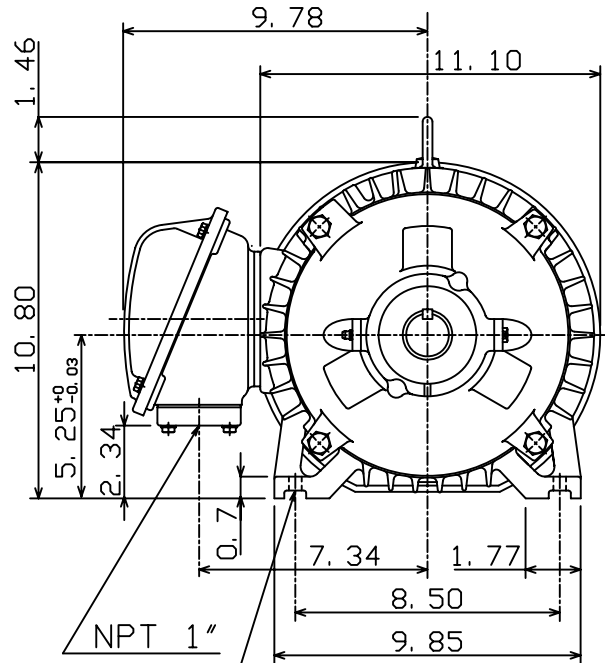
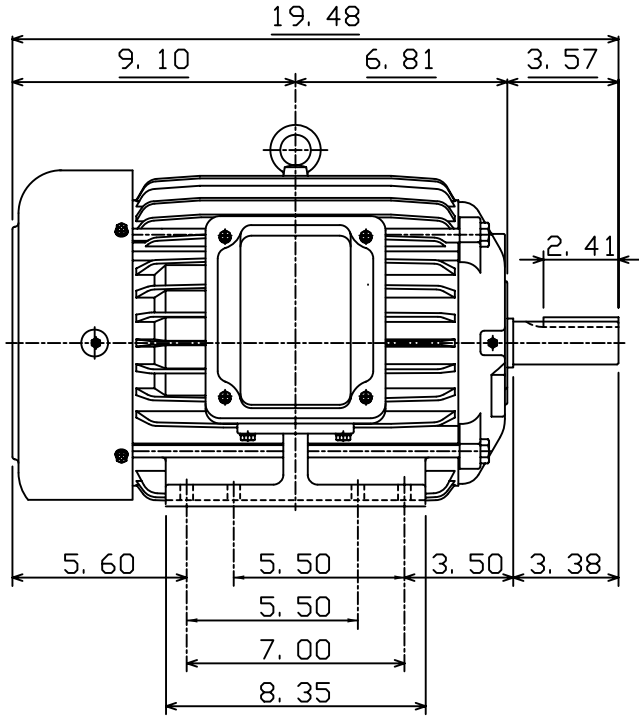

8-Ø0.41 Holes
(215T&213T)

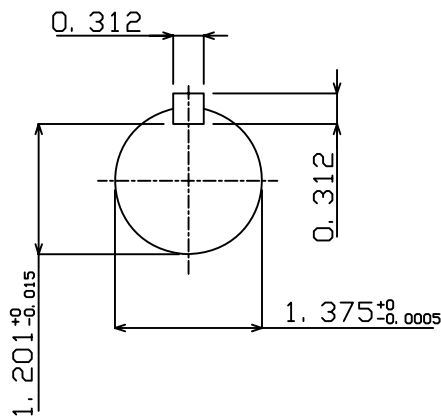

DWN.	C. S. LO	12-22-04
CHKD.	C. S. LO	12-27-04
APPD.	M. C. TSAI	12-27-04

TECO Westinghouse

DWG NO.
31057H356100